

INFLUENCE OF INDIVIDUAL PSYCHOLOGICAL TRAITS ON ATTRIBUTION TOWARD COMPUTING TECHNOLOGY

Natalia G. Falaleeva and Richard D. Johnson
University of Central Florida
nfalaleeva@bus.ucf.edu rjohnson@bus.ucf.edu

Abstract

While traditional research has focused on the computer as a tool, more recent research has begun to explore the myriad of social responses that people make toward computing technology. This paper describes an ongoing research project that focuses on social attributions toward computing technology. Marakas, Johnson, & Palmer (2000) have suggested that individual psychological responses play an important role in predicting social attributions toward computing technology. Using a controlled laboratory study, this research investigates how four key psychological traits (locus of control, general computer self-efficacy, neuroticism, and self-esteem) influence social attributions toward computing technology.

Keywords: Core self-evaluations, attribution, computing technology continuum of perspective

Background

Computing technology has become ubiquitous in organizations, with more and more jobs requiring computer skills. While users are becoming more adept at utilizing information technology, they must cope with the continued infusion of new technologies, devices and applications. Unsuccessful interactions with these technologies can result in frustration on the part of the user and can lead to further unfavorable encounters with technology. While the vast majority of research has focused on improving technology as a tool (cf. Davis, Bagozzi & Warshaw, 1989; Shneiderman, 1998), recent research has begun suggesting that individual's reactions and satisfaction with computing technology may be a result of perceived social cues within the technology (Moon & Nass, 1996).

Shneiderman (1998) and Winograd and Flores (1987) have suggested that taking a social approach to the design and understanding of technology is misguided and likely to lead to misunderstandings as to the true capabilities of computers. Others, such as Reeves and Nass (1996), suggest that social perceptions of computing are both natural and useful in the design and use of computers. Ultimately though, our language and training on computing technology has utilized a distinctly social and human-like metaphor in many instances. Winograd and Flores suggest that "as the use of a new technology changes human practices, our ways of speaking about that technology change our language and our understanding" (Winograd & Flores, 1987, p.6). Therefore, it should not be surprising that when people interact with computing technology there exists a propensity for them to interact with that technology in a distinctly social manner.

Work associated with the Computer As Social Actor (CASA: cf. Nass & Moon, 2000; Reeves & Nass, 1996) has suggested that individual's interactions with computing technology are often distinctly social in nature. The CASA research stream suggests that individuals respond to computing technology the same way they respond to humans. CASA research has provided evidence that users treat computers not simply as tools but as social actors. In their interaction with the computing technology individuals attribute human traits to the computer and react in social ways (Moon & Nass, 1996; Nass, Moon & Green, 1997; Nass & Steuer, 1993). Even though these users are aware of the fact that the computer is not a person these individuals are thought to mindlessly apply social rules to computers (Nass & Moon, 2000).

Marakas, Johnson, and Palmer have extended this work to suggest that while interactions with computing technology may be social, some may actually extend these perceptions of socialness within computing technology to a belief that the computer can

hold a social role (2000). They suggest that an individual’s social beliefs lie along a continuum and reflect generalized beliefs about the social role and capabilities of computing (Johnson, Marakas & Palmer, 2001). On one end of the continuum are those with a locally simplex perspective, who perceive computer as a tool they control and that they can leverage. At the opposite end of the continuum are those with a globally complex perspective, who view computer as an autonomous entity that they are forced to interact with and that can exert influence on them through a distinctly social role.

How this occurs is thought to be an attribution process through which people will come to understand computing technology in a more neutral tool role (tool attributions) or in a distinctly social role (social actor attributions). Attribution toward computing technology is thought to be influenced by four main factors: social character of computing technology, individual’s core self-evaluations, nature of the interaction with the technology, and presence or absence of certain attributional cues (Marakas et al., 2000). From these factors, Johnson, Marakas, & Palmer (2001) developed an empirically testable model of the Computer as Social Actor (Figure 1). Results indicate that the individual’s core self-evaluations influence their placement on the continuum and that an individual’s continuum of perspective influence attributions toward computing technology and moderate the influence of the social character of computing technology on individual’s attributions toward computing technology.¹

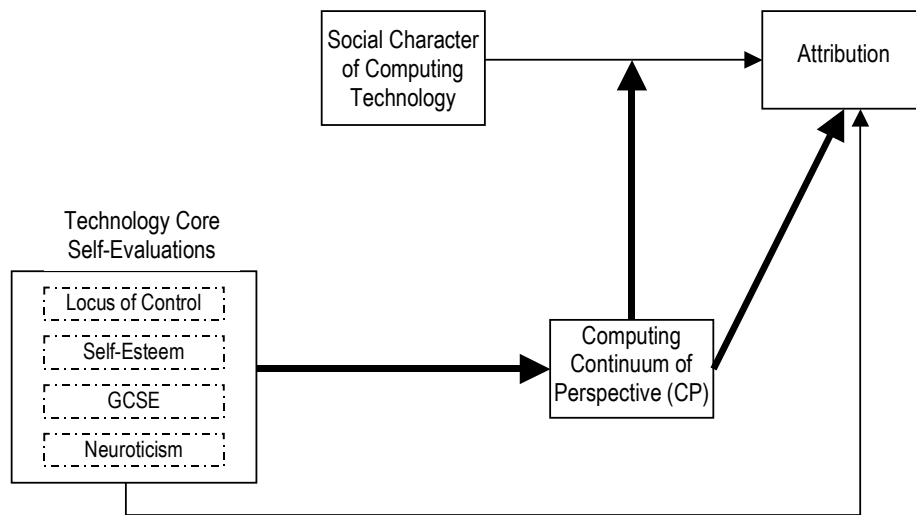

Figure 1. Model of Computer as Social Actor²

Research Model

While the role of core self-evaluations has been studied, limited work has isolated the factors of an individual’s core self-evaluations to determine which of the factors influence both an individual’s placement along the continuum as well as the ultimate attributions that are made toward computing technology. Given the strong findings of attribution researchers about the influence of psychological traits on attributions, it was surprising that the link between core self-evaluations and ultimate attributions was not found to be significant. One of the goals of this research is the deeper understanding of relationship between core self-evaluations and attributions toward computing technology. Therefore, the following model will be tested in this study (Figure 2).

¹Significant paths are enlarged in model.

² We use the term technology core self-evaluations to reflect the use of generalized computing self-efficacy within the computing domain instead of the broader and less appropriate construct for our research, generalized self-efficacy.

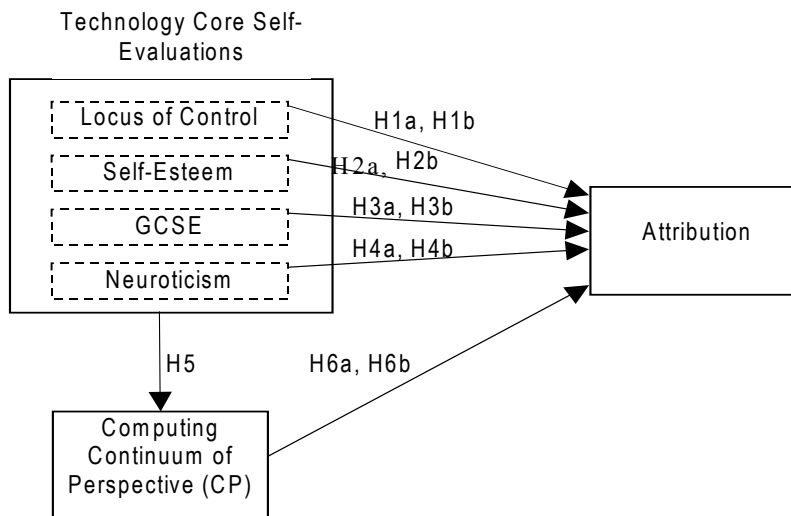

Figure 2. Research Model

Attributions Toward Computing Technology

*Attributions toward computing technology*³ can be thought of as the extent to which an individual's attribution of cause of their feelings, attitudes and performance is made toward a specific interaction with a computer. A *tool attribution* occurs when an individual's attribution of cause for his or her feelings, attitudes and performance while interacting with a specific computing technology is made to factors internal to that person (i.e. the computer is a tool). A *social actor attribution* occurs when an individual's attribution of cause of one's feelings, attitudes and performance while interacting with a computer is made to factors within the computer (i.e. the computer is an autonomous social entity).

One of the factors thought to influence attributions toward computing technology is an individual's core self-evaluations (Johnson et al., 2001; Marakas et al., 2000). Core self-evaluations reflect "fundamental, subconscious conclusion that individuals make about themselves" (Judge, Locke, Durham et al., 1998, p. 18). Core self-evaluations include self-esteem, generalized self-efficacy, neuroticism, and locus of control, and are thought to affect situational specific judgments and to lie at the base of all other appraisals. Since this study deals with the domain of computing technology, the core self-evaluations construct was redefined as technology core self-evaluations. Technology core self-evaluations are the operationalization of core self-evaluations in the field of computing technology and reflect an individual's collection of fundamental, global psychological evaluations of themselves within the domain of computing technology (Johnson et al., 2001). Of the unexpected findings from the Johnson study was that there was no direct link between core self-evaluations and attributions toward computing technology. An interesting question thus arises as to whether core self-evaluations are truly not related to attributions or if the influence of these traits is fully mediated by an individual's continuum of perspective. Given the strong findings from attribution theory, we suggest that each component of an individual's core self-evaluations does indeed play a role in influencing attributions toward computing technology.

For example, in the domain of computing technology, evidence has been reported that suggests that computerphobics not only exhibit feelings of limited control within the computing environment, but also display feelings of limited control in multiple, independent domains (Kay, 1990). This suggests that locus of control should play an important role in how people interact and perceive their interactions with computing technology. In this case, individuals with an external locus of control are expected to perceive the computer as influencing their beliefs, attitudes and performance. When an individual attributes the results of the interaction with the technology to the factors within that technology, he or she is making a social actor attribution. Conversely, individuals with internal locus of control would perceive their interaction with computing technology to attribute to factors internal to themselves, thus, perceiving technology simply as a tool and making a tool attribution.

³The theoretical basis for these attributions is attribution theory (Heider, 1958) and the model of covariation (Kelley, 1973). Discussion of the specific theories is well beyond the scope of this proposal but an excellent overview can be found in Ross & Fletcher (1985).

Hypothesis 1a: Individuals with internal locus of control will be more likely to make tool attributions than individuals with external locus of control.

Hypothesis 1b: Individuals with external locus of control will be more likely to make social actor attributions than individuals with internal locus of control.

Self-esteem refers to the individual's self-acceptance, self-liking, and self-respect (Judge, Locke & Durham, 1997). Individuals with higher self-esteem tend to perceive themselves in more positive light and make more accurate judgments of their abilities, personalities and traits, than those with low self-esteem. In the case of computing technology, individuals with higher self-esteem would be more likely to make attributions placing themselves as the locus of causality (i.e. tool attribution) whereas those with lower self-esteem would be more likely to place the computer as the locus of causality.

Hypothesis 2a: Individuals with higher self-esteem will be more likely to make tool attributions than individuals with lower self-esteem.

Hypothesis 2b: Individuals with lower self-esteem will be more likely to make social actor attributions than individuals with higher self-esteem.

Generalized computer self-efficacy refers to an individual's beliefs about their abilities across multiple computing domains (Marakas, Yi & Johnson, 1998). Self-efficacy has been shown to influence attributions (cf. Silver, Mitchell & Gist, 1995), and within the computing domain, those with higher levels of efficacy are more likely to believe themselves in control of the interactions, and those with lower levels of efficacy to be more likely to believe that computer is responsible for the interaction.

Hypothesis 3a: Individuals with higher generalized computer self-efficacy will be more likely to make tool attributions than individuals with lower general computer self-efficacy.

Hypothesis 3b: Individuals with lower generalized computer self-efficacy will be more likely to make social actor attributions than individuals with higher general computer self-efficacy.

Individuals with a high degree of neuroticism are often prone to anxiety and fear of novel situations, and tend to feel dependent and helpless (Costa & McCrae, 1988). Internally insecure individuals would be more likely to depend on the circumstances and view computing technology affecting their actions. Less neurotic individuals would be more likely to cope with interaction with computing technology more easily, and thus treat it as a tool.

Hypothesis 4a: Individuals lower on neuroticism will be more likely to make tool attributions than individuals higher on neuroticism.

Hypothesis 4b: Individuals higher on neuroticism will be more likely to make social actor attributions than individuals lower on neuroticism.

For many of the same arguments above, an individual's core self-evaluations should also influence their placement along the computing technology continuum of perspective. Underlying individual traits that influence his or her view of the surrounding environment should have an impact on the way beliefs about technology are formed. Individuals with higher technology core self-evaluations should be more likely to rely on themselves in their interaction with technology and belong to the locally simplex end of the continuum. Individuals low on technology core self-evaluations would be more likely to attribute their inabilities to external factors and lean towards globally complex end of the continuum. Empirical evidence has suggested this to be true as well (Johnson et al., 2001)

Hypothesis 5: An individual's technology core self-evaluations will be positively associated with their computing technology continuum of perspective.

As Bandura (1986) suggests, an individual's previous experience and attitudes shape their behaviors and attitudes in new situations and environments. Thus we would expect that an individual's generalized beliefs about computing technology should influence their attributions toward a specific interaction with a unique technology. In fact, recent research has provided evidence to this effect. (Johnson et al., 2001).

Hypothesis 6a: Individuals with a more locally simplex continuum of perspective will be more likely to make tool attributions than individuals with a more globally complex continuum of perspective.

Hypothesis 6b: Individuals with globally complex continuum of perspective will be more likely to make social actor attributions than individuals with locally simplex continuum of perspective.

Study Methodology

We plan to test the hypotheses using a controlled laboratory study using undergraduate and graduate students from throughout a southeastern university. To stimulate differential responses, the subjects will interact with a vacation planning software program that uses an animated agent to assist the users in choosing vacation in the mid-Atlantic of the United States⁴. Constructs will be measured as follows:

Construct	Items	Type	Source
Locus of Control	11	7 point-Lickert	Levenson(1973)
Self-Esteem	10	7 point-Lickert	Rosenberg (1965)
Neuroticism	9	7 point-Lickert	Eysenck & Eysenck(1968)
Continuum of Perspective	13	7 point-Lickert	Johnson et al. (2001)
Attributions	17	7 point-Lickert	Johnson et al. (2001)
GCSE	7	Strength: Yes/No Magnitude 10-100	Marakas & Johnson (2001)

Conclusion

This study increases our understanding of the attributions towards computing technology and how they are formed. With computers being ubiquitous in the organizations it is important to facilitate most natural interaction of the user and technology. When people attribute success to factors beyond their control, they are less likely to persist in the face of obstacles (Bandura, 1986; Kelley, 1973). If individuals indeed attribute social agency to computing technology, it may prevent them from further success. Better understanding of the effects of individual traits on the perception of technology can help improve training methods in organizations and facilitate easier interaction with computing technology.

References

- Bandura, A. "Social Foundations of Thought and Action: A Social Cognitive Theory," Prentice-Hall, Englewood Cliffs, NJ, 1986, pp. 390-453.
- Costa, P.T.J., and McCrae, R.R. "Personality in adult-hood: A six-year longitudinal study of self-reports and spouse ratings on the NEO personality inventory," *Journal of Personality and Social Psychology* (54) 1988, pp 853-863.
- Davis, F.D., Bagozzi, R.P., and Warshaw, P.R. "User Acceptance of Computer Technology: A Comparison of Two Theoretical Models," *Management Science* (35:8) 1989, pp 982-1002.
- Eysenck, H.J., and Eysenck, S.B.G. *Manual for the Eysenck Personality Inventory* Educational and Industrial Testing Service, San Diego, 1968.
- Heider, F. *The psychology of interpersonal relations* Wiley, New York, 1958.
- Johnson, R.D., Marakas, G.M., and Palmer, J.W. "Tool or Social Actor? Factors Contributing to Differential Social Attributions Toward Computing Technology," in: *University of Central Florida Working Paper*, Orlando, FL, 2001.
- Judge, T.A., Locke, E.A., and Durham, C.C. "The dispositional causes of job satisfaction: a core evaluations approach," *Research in Organizational Behavior* (19) 1997, pp 151-188.

⁴The software was designed using Visual Basic 6.0®, Microsoft Agent 2.0®, and the Lernout & Hauspie® TruVoice Text to Speech Engine. Results from Johnson (2001) indicate that subjects were able to perceive this interface as being differentially social from a traditional interface.

- Judge, T.A., Locke, E.A., Durham, C.C., and Kluger, A.N. "Dispositional Effects on Job and Life Satisfaction: the Role of Core Evaluations," *Journal of Applied Psychology* (83:1) 1998, pp 17-34.
- Kay, R.H. "The relation between locus of control and computer literacy," *Journal of Research on Computing in Education* 1990.
- Kelley, H.H. "The Process of Causal Attribution," *American Psychologist*, February 1973, pp 107-128.
- Levenson, H. "Multidimensional Locus of Control in Psychiatric Patients," *Journal of Consulting and Clinical Psychology* (41:3) 1973, pp 397-404.
- Marakas, G.M., and Johnson, R.D. "Development of a measure of computer self-efficacy at the general and task specific level," in: *Working Paper Series, Indiana University*, 2001.
- Marakas, G.M., Johnson, R.D., and Palmer, J.W. "A theoretical model of differential social attributions toward computing technology: when the metaphor becomes the model," *International Journal of Human-Computer Studies* (51:4) 2000, pp 719-750.
- Marakas, G.M., Yi, M.Y., and Johnson, R.D. "The multilevel and multifaceted character of computer self-efficacy: Toward clarification of the construct and an integrative framework for research," *Information Systems Research* (9:2) 1998, pp 126-163.
- Moon, Y., and Nass, C. "How "Real" Are Computer Personalities? A Psychological Responses to Personality Types in Human-Computer Interaction," *Communication Research* (23:6), December 1996, pp 651-674.
- Nass, C., and Moon, Y. "Machines and Mindlessness: Social Responses to Computers," *Journal of Social Issues* (56:1) 2000, pp 81-103.
- Nass, C., Moon, Y., and Green, N. "Are Machines Gender Neutral? Gender-Stereotypic Responses to Computers with Voices," *Journal of Applied Social Psychology* (27:10) 1997, pp 864-876.
- Nass, C., and Steuer, J. "Voices, Boxes, and Sources of Messages. Computers and Social Actors," *Human Communication Research* (19:4) 1993, pp 504-527.
- Reeves, B., and Nass, C. *The Media Equation: How People Treat Computers, Television, and New Media Like Real People and Places* Cambridge University Press CSLI, Stanford, CA, 1996.
- Rosenberg, M. *Society and Adolescent Image* Princeton University Press, Princeton, 1965.
- Ross, M., and Fletcher, G.J.O. "Attribution and social perception," in: *The Handbook of Social Psychology*, G. Lindzey and E. Aronson (eds.), Random House, New York, 1985, pp. 73-122.
- Shneiderman, B. *Designing the User Interface: Strategies for Effective Human-Computer Interaction* Addison Wesley Longman, 1998.
- Silver, W.S., Mitchell, T.R., and Gist, M.E. "Responses to successful and unsuccessful performances: The moderating effect of self-efficacy on the relationship between performance and attributions," *Organizational Behavior and Human Decision Processes* (62:3) 1995, pp 286-299.
- Winograd, T., and Flores, F. *Understanding Computers and Cognition: A New Foundation for Design* Addison-Wesley, Reading, MA, 1987.